



* Customer : KTC

SPECIFICATION

[SBIHT120E]

| Seoul semiconductor | | | Customer |
|--------------------------|------------|-------------|-------------|
| Drawn by | Checked by | Approved by | Approved by |
| IT. Divison2 D.I Kang | | | |
| 2015.10.02 | | | |

Direct TV Application

Top View LED

SBIHT120E

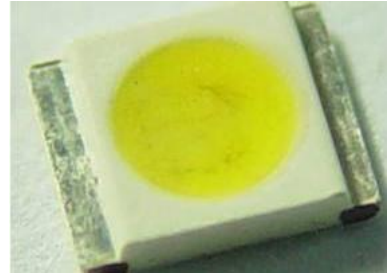

Product Brief

Description

- 1-chip in one package
- SMT solderability
- Own patent reserved
- RoHS Compliant
- Low Thermal Resistance
- Pb-free Reflow Soldering application
- SBIHT120E is very useful Top View LED in back light unit application

Features and Benefits

- 3.5mm x 2.8mm x 0.6mm
- White colored SMT package

Key Applications

- Flat Backlighting (LCD, Display)
- MNT, TV etc.
- Coupling into Light Guide Panel
- AV systems

Table of Contents

| Index | |
|---------------------------------------|--|
| • Product Brief | |
| • Table of Contents | |
| • Performance Characteristics | |
| • Characteristic Diagram | |
| • Reliability Test | |
| • Color Bin Structure | |
| • Mechanical Dimension | |
| • Packaging Information | |
| • Reflow Soldering Characteristics | |
| • Handling of Silicone Resin for LEDs | |
| • Precaution For Use | |
| • Company Information | |

Performance Characteristics

Table 1. Absolute Maximum Ratings ($T_a = 25^\circ\text{C}$)

| Parameter | Symbol | Value | Unit |
|-----------------------|------------------------|------------|------------------|
| Power Dissipation | P_d^{*1} | 1,520 | mW |
| DC Forward Current | I_F^{*2} | 400 | mA |
| Peak Forward Current | I_{FM}^{*3} | 700 | mA |
| Operating Temperature | T_{opr} | -30 ~ +85 | $^\circ\text{C}$ |
| Storage Temperature | T_{stg} | -40 ~ +100 | $^\circ\text{C}$ |
| Junction Temperature | $T_j \text{ max}^{*4}$ | 125 | $^\circ\text{C}$ |

Notes :

- (1) Care is to be taken that power dissipation does not exceed the absolute maximum rating of the product.
- (2) 1/10 Duty Cycle @ 1KHz .
- (3) The absolute maximum ratings do not guarantee the lifetime of LED.

Table 2. Electro Optical Characteristics ($T_a = 25^\circ\text{C}$)

| Parameter | Symbol | Condition | Min | Typ | Max | Unit |
|---|-----------------|-------------------------------------|--------|-------|------|------|
| Forward Voltage ^{*1} | V_F | $I_F = 280\text{mA}$ | 3.0 | 3.3 | 3.6 | V |
| Reverse Voltage | V_R | $I_R = 5\text{mA}$ | - | 0.9 | 1.2 | V |
| Luminous Intensity ^{*2} | I_V | $I_F = 280\text{mA}$ | 26.0 | 28.5 | - | cd |
| Luminous Flux | Flux | $I_F = 280\text{mA}$ | - | 86.4 | - | lm |
| Viewing Angle ^{*3} | $2\theta_{1/2}$ | $I_F = 280\text{mA}$ | - | 120 | - | deg. |
| CIE x | Cx | $I_F = 280\text{mA}$ | - | 0.275 | - | - |
| CIE y | Cy | $I_F = 280\text{mA}$ | - | 0.240 | - | - |
| Thermal Resistance (Junction to Solder) ^{*4} | $R_{th(j-s)}$ | $I_F = 400\text{mA}$ | - | - | 37.0 | K/W |
| ESD Sensitivity | V_F | HBM | 5 | - | - | kV |
| Life Time ^{*5} | V_F | $T_j < 115^\circ\text{C}$ @400mA | 30,000 | - | - | Hrs |

Notes :

- (1) Forward voltage measurement allowance is $\pm 0.1\text{V}$
- (2) The luminous intensity I_V is measured at the peak of the spatial pattern which may not be aligned with the mechanical axis of the LED package. Luminous Intensity Measurement allowance is $\pm 10\%$.
- (3) $2\theta_{1/2}$ is the off-axis where the luminous intensity is 1/2 of the peak intensity.
- (4) R_{th} can be different by T_s at the ambient temperature ($T_a = 70^\circ\text{C}$, PCB = MCPCB)
- (5) Failure means that luminous intensity degrades to 50% of initial value .(L50) The lifetime is estimated by the measured datum at 3khr. (MTTF)

Characteristic Diagram

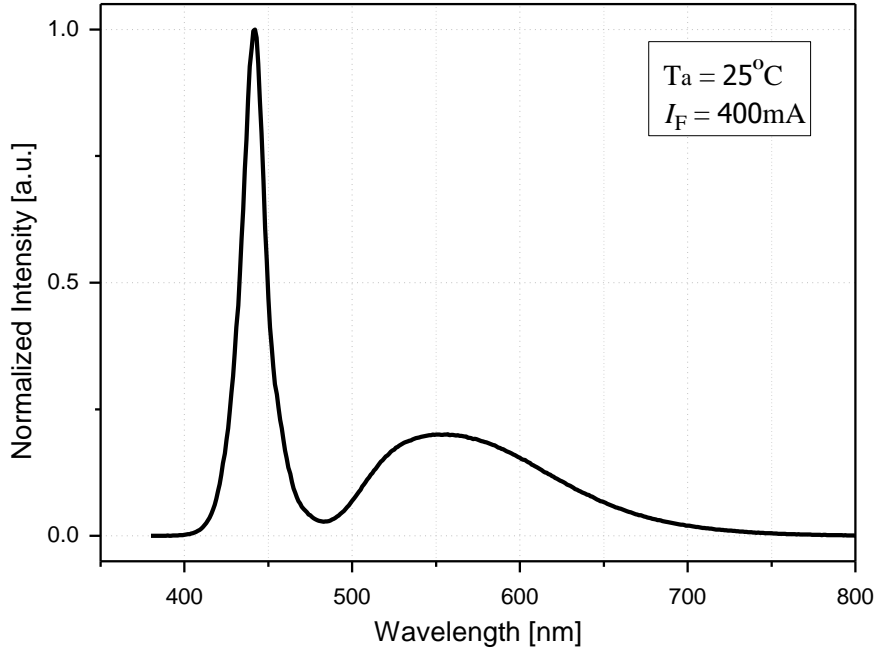
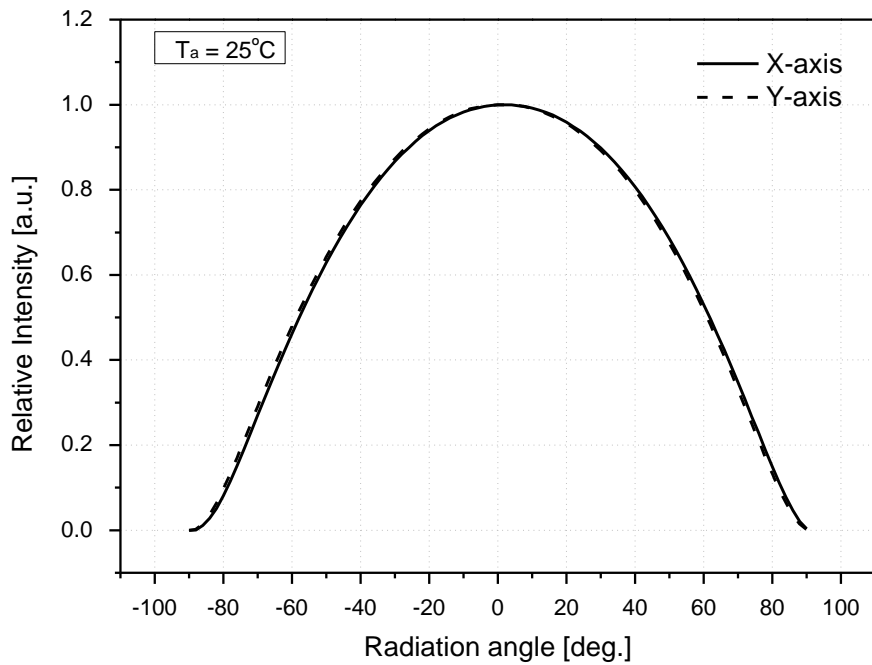
Fig 1. Color Spectrum, $T_a = 25^\circ\text{C}$, $I_F = 400\text{mA}$, RH30%

Fig 2. Radiant pattern, $T_a = 25^\circ\text{C}$

Characteristic Diagram

Fig 3. Forward Voltage vs. Forward Current , $T_a = 25^\circ\text{C}$

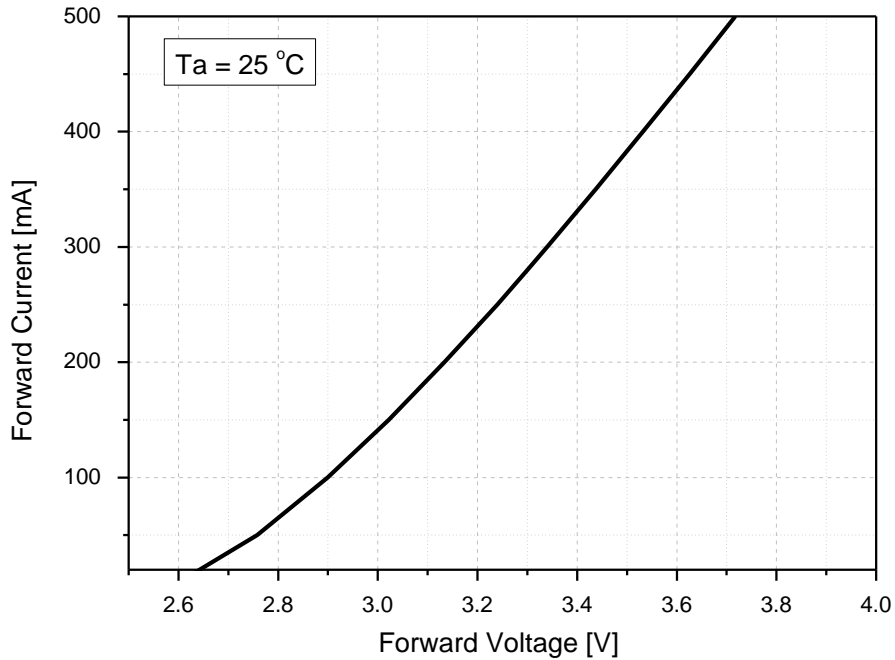
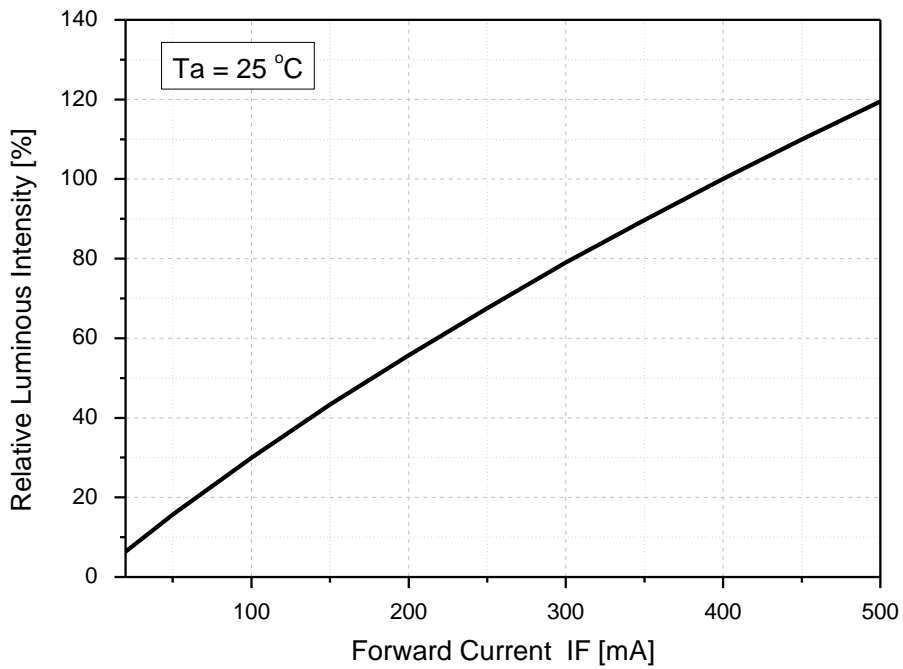
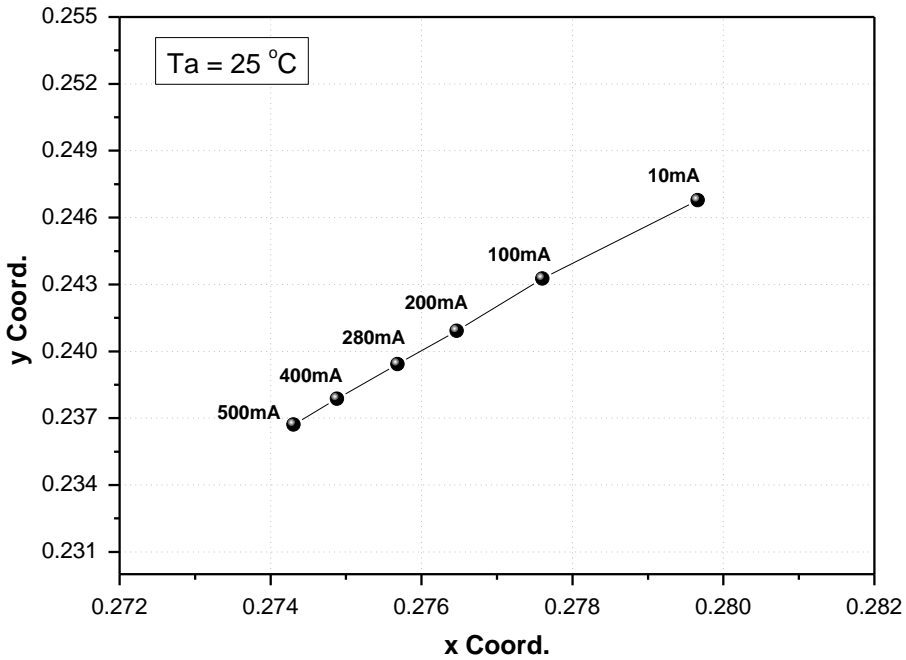
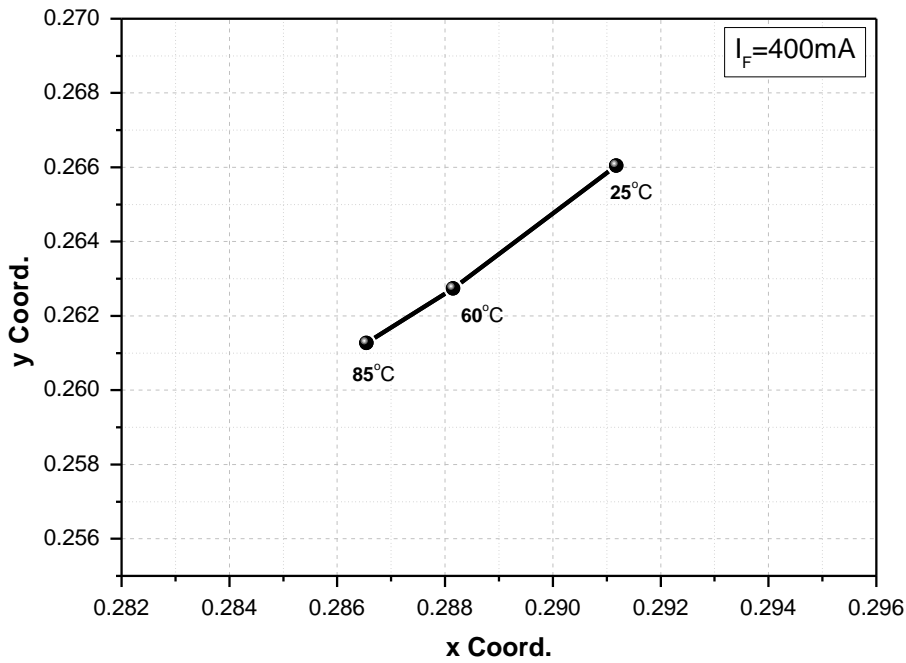

Fig 4. Forward Current vs. Relative Luminous Intensity, $T_a = 25^\circ\text{C}$



Characteristic Diagram

Fig 5. Forward Current vs. CIE X, Y Shift, $T_a = 25^\circ\text{C}$

Fig 6. Color Coordinate vs. Ambient Temperature, $I_F = 400\text{mA}$

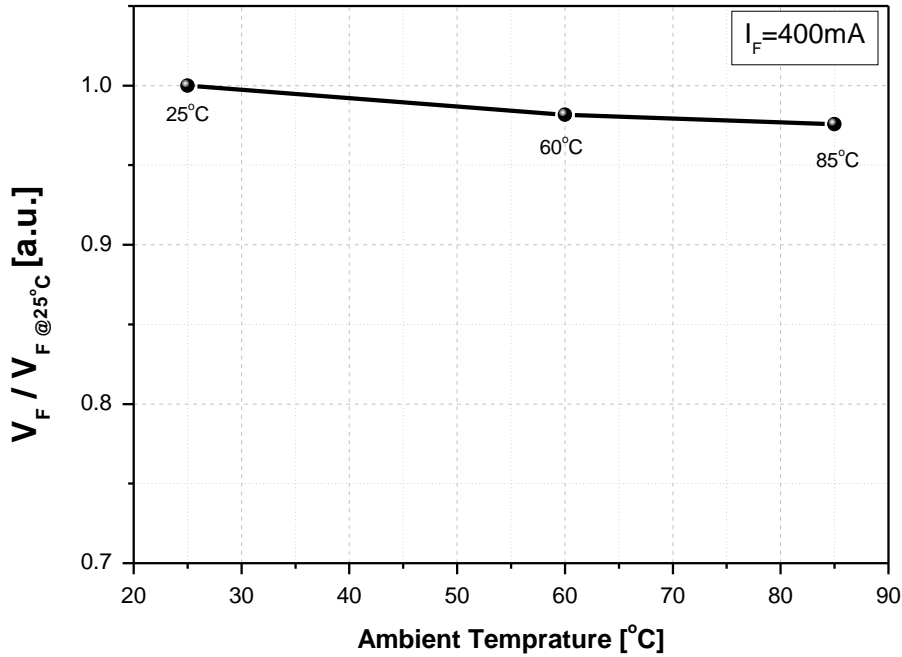
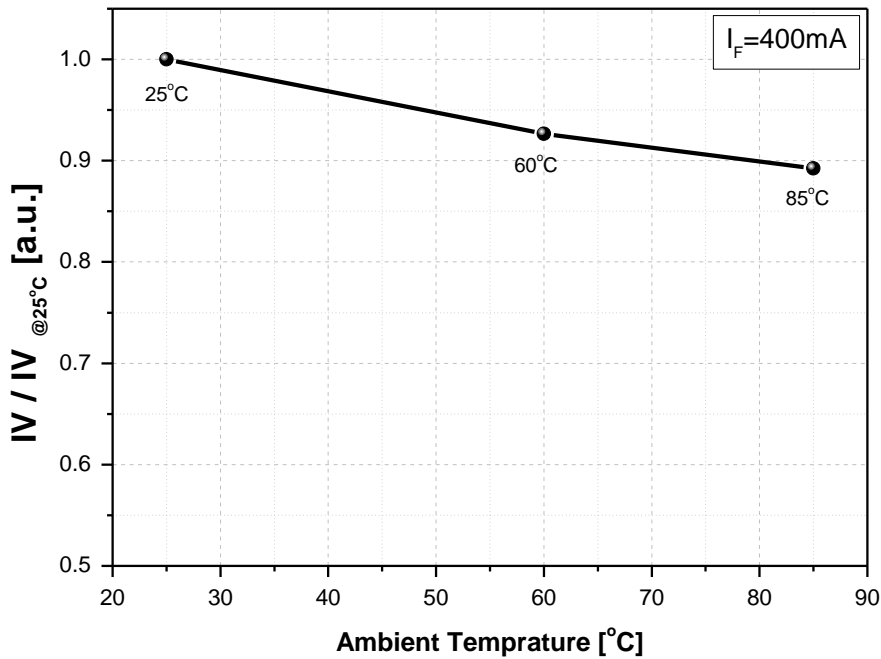
Characteristic Diagram

Fig 7. Forward Voltage vs. Ambient Temperature, $I_F=400\text{mA}$

Fig 8. Relative Luminosity vs. Ambient Temperature, $I_F=400\text{mA}$

Reliability Test

Table 3. TEST ITEMS AND RESULTS

| Item | Reference | Test Condition | Duration / Cycle | Number of Damage |
|------------------------------|--------------------------|---|------------------|------------------|
| Thermal Shock | Internal Reference | $T_a = -40^\circ\text{C}$ (30MIN) ~ 85°C (30MIN) | 100 Cycle | 0/20 |
| Temperature Cycle | JEITA ED-4701 100 105 | $-40^\circ\text{C} \sim 25^\circ\text{C} \sim 100^\circ\text{C} \sim 25^\circ\text{C}$ (30min) (5min) (30min) (5min) | 100 cycle | 0/20 |
| Life Test | Internal Reference | $T_a = 25^\circ\text{C}$, $I_F = 400\text{mA}$ | 1,000 Hours | 0/20 |
| High Temperature Life Test | Internal Reference | $T_a = 60^\circ\text{C}$, $I_F = 400\text{mA}$ | 1,000 Hours | 0/20 |
| High Humidity Heat Life Test | Internal Reference | $T_a = 60^\circ\text{C}$, RH = 90%, $I_F = 400\text{mA}$ | 1,000 Hours | 0/20 |

Table 4. Criteria for Judging the Damage

| Item | Symbol | Condition | Criteria for Judgment | |
|--------------------|--------|----------------------|-----------------------|------------------------------|
| | | | MIN | MAX |
| Forward Voltage | V_F | $I_F = 400\text{mA}$ | - | $I.V. \cdot^{*1} \times 1.2$ |
| Luminous Intensity | I_V | $I_F = 400\text{mA}$ | $I.V. \times 0.7$ | - |

Notes :

*⁽¹⁾ I.V. : Initial Value

Color Bin Structure

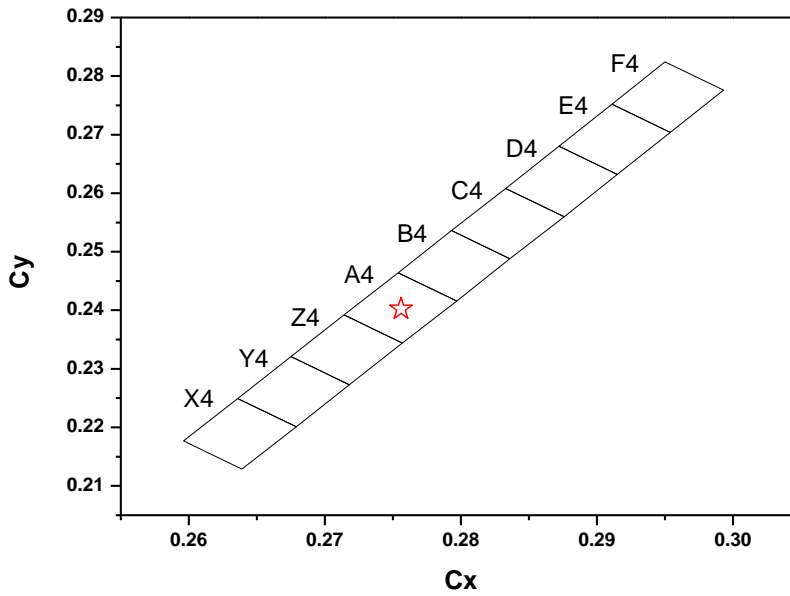
CIE Chromaticity Diagram

| RANK | x1 | y1 | x2 | y2 |
|------|--------|--------|--------|--------|
| | x3 | y3 | x4 | y4 |
| X4 | 0.2596 | 0.2177 | 0.2636 | 0.2249 |
| | 0.2679 | 0.2201 | 0.2639 | 0.2129 |
| Y4 | 0.2636 | 0.2249 | 0.2675 | 0.2321 |
| | 0.2718 | 0.2273 | 0.2679 | 0.2201 |
| Z4 | 0.2675 | 0.2321 | 0.2714 | 0.2392 |
| | 0.2757 | 0.2344 | 0.2718 | 0.2273 |
| A4 | 0.2714 | 0.2392 | 0.2754 | 0.2464 |
| | 0.2797 | 0.2416 | 0.2757 | 0.2344 |
| B4 | 0.2754 | 0.2464 | 0.2793 | 0.2536 |
| | 0.2836 | 0.2488 | 0.2797 | 0.2416 |
| C4 | 0.2793 | 0.2536 | 0.2833 | 0.2608 |
| | 0.2876 | 0.256 | 0.2836 | 0.2488 |
| D4 | 0.2833 | 0.2608 | 0.2872 | 0.268 |
| | 0.2915 | 0.2632 | 0.2876 | 0.256 |
| E4 | 0.2872 | 0.268 | 0.2911 | 0.2752 |
| | 0.2954 | 0.2704 | 0.2915 | 0.2632 |
| F4 | 0.2911 | 0.2752 | 0.295 | 0.2824 |
| | 0.2993 | 0.2776 | 0.2954 | 0.2704 |

* Measurement Uncertainty of the Color Coordinates is ± 0.007

Color Bin Structure

Table 5. Bin Code description
Part Number : SBIHT120E

| Bin Code | | | | | | | | | | | |
|--------------------|--|--|-----------|--|--|----------|--|--|-----------------|--|--|
| Luminous Intensity | | | CIE | | | LMP | | | Forward Voltage | | |
| T280 | | | A4 | | | S | | | Z32 | | |

| Luminous Intensity (cd) @ I _F = 280mA | | |
|---|------|------|
| Bin Code | Min. | Max. |
| T260 | 26.0 | 27.0 |
| T270 | 27.0 | 28.0 |
| T280 | 28.0 | 29.0 |
| T290 | 29.0 | 30.0 |
| T300 | 30.0 | 31.0 |

| Color Rank @ I _F = 280mA |
|--|
| X4~F4 |

| Peak Wavelength[nm] @ I _F = 280mA | | |
|---|-------|-------|
| Bin Code | Min. | Max. |
| R | 439.5 | 442.0 |
| S | 442.0 | 444.5 |
| T | 444.5 | 447.0 |
| U | 447.0 | 449.5 |

| Forward Voltage[V] @ I _F = 280mA | | |
|--|------|------|
| Bin Code | Min. | Max. |
| Z30 | 3.0 | 3.2 |
| Z32 | 3.2 | 3.4 |
| Z34 | 3.4 | 3.6 |

 Available Ranks

Mechanical Dimensions

(Tolerance: ± 0.1 , Unit: mm)

PKG Outline dimension

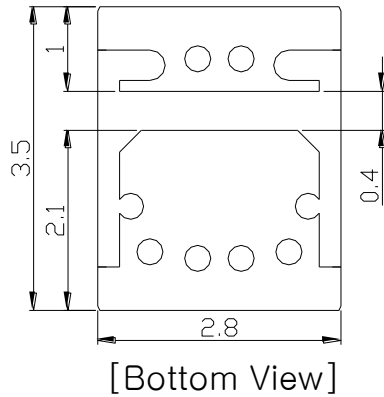
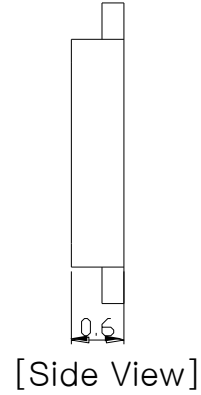
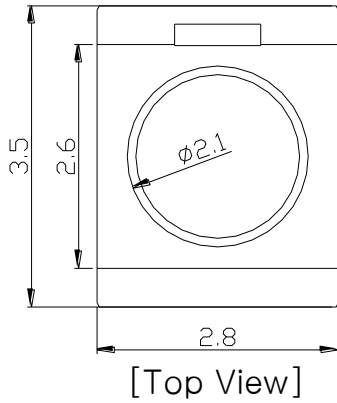

< Inner circuit >

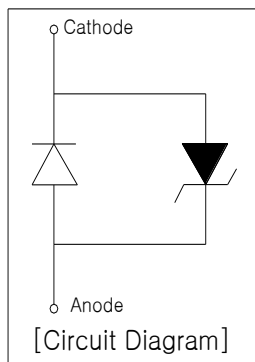

< Recommended Solder Pattern >

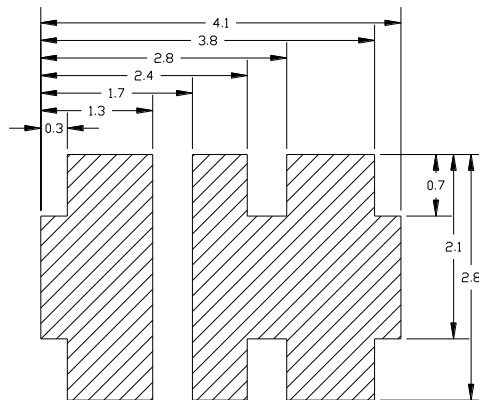

Emitter Tape & Reel Packaging

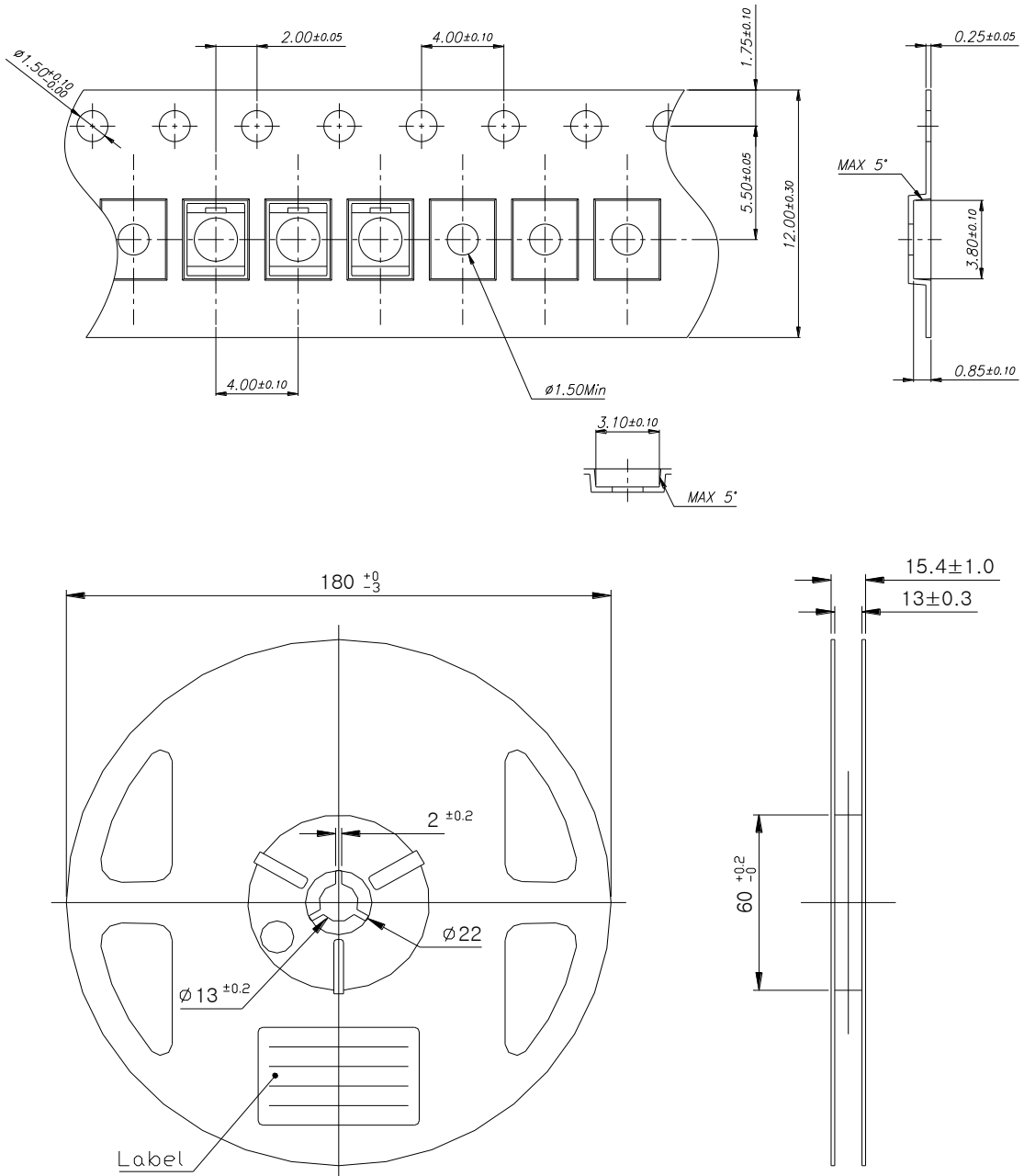

(Tolerance: ± 0.2 , Unit: mm)

- (1) Quantity : 3500pcs/Reel
- (2) Cumulative Tolerance : Cumulative Tolerance/10 pitches to be ± 0.2 mm
- (3) Adhesion Strength of Cover Tape : Adhesion strength to be 0.1-0.7N when the cover tape is turned off from the carrier tape at the angle of 10° to the carrier tape
- (4) Package : P/N, Manufacturing data Code No. and quantity to be indicated on a damp proof Package

Emitter Tape & Reel Packaging

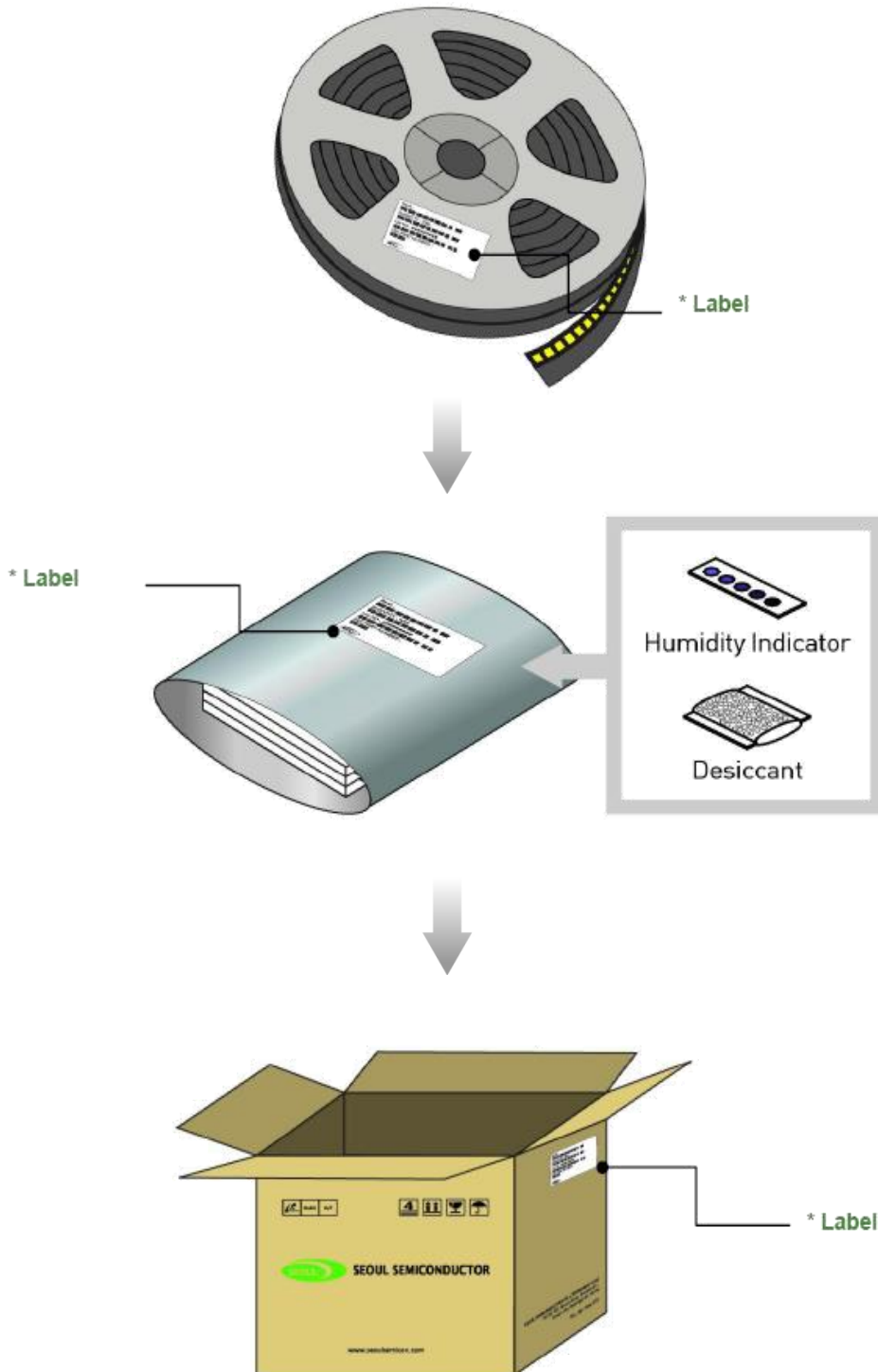

Product Nomenclature

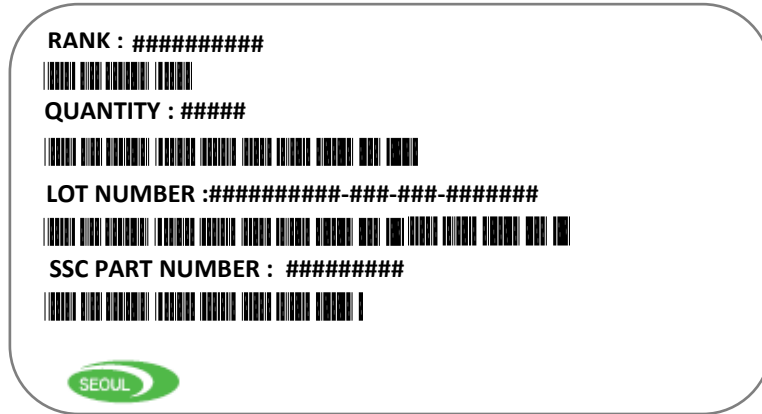
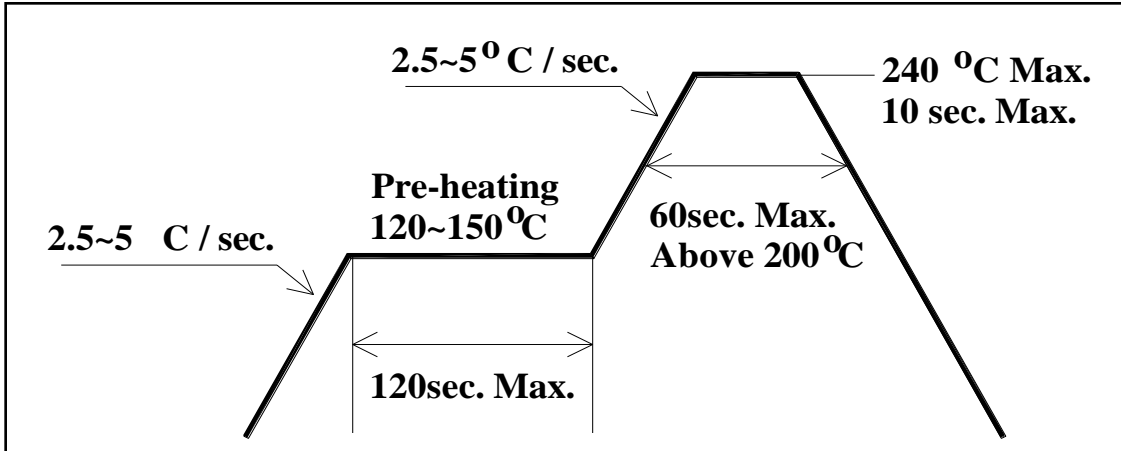

Table 6. Lot Numbering System : Y₁Y₂Y₃Y₄Y₅Y₆Y₇Y₈Y₉Y₁₀-Y₁₁Y₁₂Y₁₃-Y₁₄Y₁₅Y₁₆-Y₁₇Y₁₈Y₁₉Y₂₀Y₂₁Y₂₂Y₂₃

| Symbol | Meaning | Example |
|---|-----------------|--|
| Y ₁ Y ₂ Y ₃ Y ₄ Y ₅ | THE DATE | 09A23 (Year : 09, A : Month, 23 : day) |
| Y ₆ Y ₇ Y ₈ Y ₉ Y ₁₀ | SSC's Number | Ex) S0017 0001~9999 allowance |
| Y ₁₁ Y ₁₂ Y ₁₃ -Y ₁₄ Y ₁₅ Y ₁₆ | Order of Taping | 014-001 |
| Y ₁₇ Y ₁₈ Y ₁₉ Y ₂₀ Y ₂₁ Y ₂₂ Y ₂₃ | SSC's Number | 7250667(Automatic) |

Reflow Soldering Characteristics

(1) Lead Solder



| Lead Free Solder | |
|--------------------------|---------------|
| Pre-heat | 120~150 °C |
| Pre-heat time | 120 sec. Max. |
| Peak-Temperature | 240 °C Max. |
| Soldering time Condition | 10 sec. Max. |

(2) Lead-Free Solder

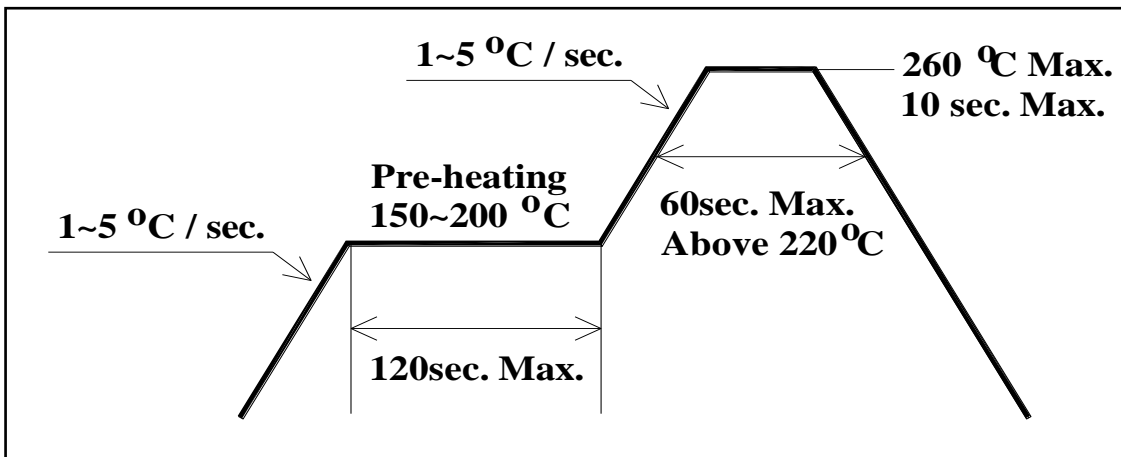

| Lead Free Solder | |
|--------------------------|---------------|
| Pre-heat | 150~200 °C |
| Pre-heat time | 120 sec. Max. |
| Peak-Temperature | 260 °C Max. |
| Soldering time Condition | 10 sec. Max. |

(3) Hand Soldering conditions

Not more than 3 seconds @MAX 350°C, under Soldering iron.

Handling of Silicone Resin for LEDs

- (1) During processing, mechanical stress on the surface should be minimized as much as possible. Sharp objects of all types should not be used to pierce the sealing compound.

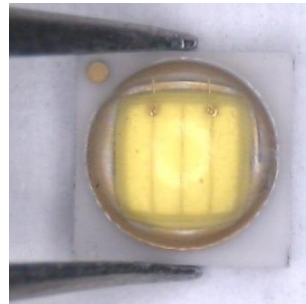

- (2) In general, LEDs should only be handled from the side. By the way, this also applies to LEDs without a silicone sealant, since the surface can also become scratched.
- (3) When populating boards in SMT production, there are basically no restrictions regarding the form of the pick and place nozzle, except that mechanical pressure on the surface of the resin must be prevented. This is assured by choosing a pick and place nozzle which is larger than the LED's reflector area.
- (4) Silicone differs from materials conventionally used for the manufacturing of LEDs. These conditions must be considered during the handling of such devices. Compared to standard encapsulants, silicone is generally softer, and the surface is more likely to attract dust. As mentioned previously, the increased sensitivity to dust requires special care during processing. In cases where a minimal level of dirt and dust particles cannot be guaranteed, a suitable cleaning solution must be applied to the surface after the soldering of components.
- (5) Seoul Semiconductor suggests using isopropyl alcohol for cleaning. In case other solvents are used, it must be assured that these solvents do not dissolve the package or resin. Ultrasonic cleaning is not recommended. Ultrasonic cleaning may cause damage to the LED.
- (6) Please do not mold this product into another resin (epoxy, urethane, etc) and do not handle this product with acid or sulfur material in sealed space.
- (7) Avoid leaving fingerprints on silicone resin parts.

Precaution for Use

(1) Storage conditions

Keep the product in a dry box or a desiccator with a desiccant in order to prevent moisture absorption.

a. Keep it at a temperature in the range from 5°C to 30°C and at a humidity of less than 50% RH. The product should be kept within a year.

(2) After opening the package .

When soldering, this could result in a decrease of the photoelectric effect or light intensity.

a. Soldering should be done right after mounting the product.

b. Keep the temperature in the range from 5°C to 30°C and the humidity at less than 60%.

Soldering should be done within 7 days after opening the desiccant package.

If the product has been exposed for more than 7 days after opening the package or the indicating color of the desiccant changes, the product must be baked at a temperature between $65 \pm 5^\circ\text{C}$ for less than 24 hours.

An unused and unsealed product should be repacked in a desiccant package and kept sealed in a dry atmosphere.

Stored at a humidity of less than 10% RH.

(3) Precautions for use

Any external mechanical force or excessive vibration should not be applied to the product during cooling after soldering, and it is preferable to avoid rapid cooling.

The product should not be mounted on a distorted part of PCB.

Gloves or wrist bands for ESD(Electric Static Discharge) should be wore in order to prevent ESD and surge damage, and all devices and equipments must be grounded to the earth.

(4) Miscellaneous

Radiation resistance is not considered.

When cleaning the product, any kind of fluid such as water, oil and organic solvent must not be used and IPA(Isopropyl Alcohol) must be used.

When using the product, operating current should be settled in consideration of the maximum ambient temperature.

Its appearance or specification for improvement is subject to change without notice.

Precaution for Use

(5) LEDs are sensitive to Electro-Static Discharge (ESD) and Electrical Over Stress (EOS).

Below is a list of suggestions that Seoul Semiconductor purposes to minimize these effects.

a. ESD (Electro Static Discharge)

Electrostatic discharge (ESD) is defined as the release of static electricity when two objects come into contact. While most ESD events are considered harmless, it can be an expensive problem in many industrial environments during production and storage. The damage from ESD to LEDs may cause the product to demonstrate unusual characteristics such as:

- Increase in reverse leakage current lowered turn-on voltage
- Abnormal emissions from the LED at low current

The following recommendations are suggested to help minimize the potential for an ESD event.

One or more recommended work area suggestions:

- Ionizing fan setup
- ESD table/shelf mat made of conductive materials
- ESD safe storage containers

One or more personnel suggestion options:

- Antistatic wrist-strap
- Antistatic material shoes
- Antistatic clothes

Environmental controls:

- Humidity control (ESD gets worse in a dry environment)

Precaution for Use

b. EOS (Electrical Over Stress)

Electrical Over-Stress (EOS) is defined as damage that may occur when an electronic device is subjected to a current or voltage that is beyond the maximum specification limits of the device.

The effects from an EOS event can be noticed through product performance like:

- Changes to the performance of the LED package
(If the damage is around the bond pad area and since the package is completely encapsulated the package may turn on but flicker show severe performance degradation.)
- Changes to the light output of the luminaire from component failure
- Components on the board not operating at determined drive power

Failure of performance from entire fixture due to changes in circuit voltage and current across total circuit causing trickle down failures. It is impossible to predict the failure mode of every LED exposed to electrical overstress as the failure modes have been investigated to vary, but there are some common signs that will indicate an EOS event has occurred:

- Damaged may be noticed to the bond wires (appearing similar to a blown fuse)
- Damage to the bond pads located on the emission surface of the LED package
(shadowing can be noticed around the bond pads while viewing through a microscope)
- Anomalies noticed in the encapsulation and phosphor around the bond wires.
- This damage usually appears due to the thermal stress produced during the EOS event.

c. To help minimize the damage from an EOS event Seoul Semiconductor recommends utilizing:

- A surge protection circuit
- An appropriately rated over voltage protection device
- A current limiting device



Company Information

Published by

Seoul Semiconductor © 2013 All Rights Reserved.

Company Information

Seoul Semiconductor (www.SeoulSemicon.com) manufactures and packages a wide selection of light emitting diodes (LEDs) for the automotive, general illumination/lighting, Home appliance, signage and back lighting markets. The company is the world's fifth largest LED supplier, holding more than 10,000 patents globally, while offering a wide range of LED technology and production capacity in areas such as "nPola", "Acrich", the world's first commercially produced AC LED, and "Acrich MJT - Multi-Junction Technology" a proprietary family of high-voltage LEDs.

The company's broad product portfolio includes a wide array of package and device choices such as Acrich and Acirch2, high-brightness LEDs, mid-power LEDs, side-view LEDs, and through-hole type LEDs as well as custom modules, displays, and sensors.

Legal Disclaimer

Information in this document is provided in connection with Seoul Semiconductor products. With respect to any examples or hints given herein, any typical values stated herein and/or any information regarding the application of the device, Seoul Semiconductor hereby disclaims any and all warranties and liabilities of any kind, including without limitation, warranties of non-infringement of intellectual property rights of any third party. The appearance and specifications of the product can be changed to improve the quality and/or performance without notice.



Revision History

| Revision | Date | Page | Remarks |
|----------|-------------|------|---|
| 0.0 | Oct-02-2015 | All | Initial release of preliminary data sheet applied |